

Composting Yard Waste

Compost is decomposed plant material mixed with some soil. Some gardeners may consider compost a form of fertilizer, but its most important function is to increase the organic matter content of vegetable or flower garden soil, enhancing tilth. Adding compost to the garden soil improves the soil structure by making it more granular. Building up organic matter in a soil increases both its water-holding capacity and its productive ability. Plants growing in such soil can better withstand drought conditions. Vegetables, flowers, lawns, and small fruits all grow best in soils that have a high organic content.

Although good yields are possible by adding to the soil only mineral fertilizers—or only organic materials—best results can be obtained by using both. Garden crops receive the benefits of humus from the organic matter, and higher mineral nutrients from the commercial fertilizer. The humus helps hold needed nutrients in the soil so plants can use them readily.

Perhaps the best way to dispose of yard and garden wastes is by composting—either on a large scale by municipalities or by individuals in backyards. The 1989 Iowa Solid Waste Reduction Act prohibits dumping yard waste into sanitary landfills, and many cities forbid leaf burning. Composting is a relatively easy, inexpensive procedure yielding valuable humus that can be returned to garden soil, or used as mulch around landscape plantings.

Materials for making a compost pile

Nitrogen, water, oxygen, and soil must be present for decomposition of the plant material in a compost pile to occur. The microorganisms in the soil decompose the plant material, which is mostly carbon by oxidation. Because the microbes use the carbon, two-thirds of it is converted into carbon dioxide that is released into the atmosphere. One-third passes into microbe cells and thus stays within the pile.

Loss of carbon from a compost pile is evidenced both by the generated heat and the reduction of the pile's weight and volume as decomposition proceeds.

Nitrogen (also found in raw organic materials) is used by the microbes for protein synthesis. In the composting process, the ratio of carbon (C) to nitrogen (N) in the plant materials is important. Adequate nitrogen must be available for the microbes so they can rapidly increase their numbers, and thus speed the decomposition process. Soil commonly contains a carbon-to-nitrogen (C:N) ratio of 10:1. Thus, an ideal material for composting would contain 30 parts of carbon to 1 part nitrogen, so that 20 parts (or two-thirds) of the carbon could go off into the atmosphere as CO_2 , and leave 10 parts (or one-third) of the total carbon in the composting material for a nitrogen ratio of 10:1. When there is insufficient nitrogen (plant materials with high C:N), the microbe population cannot grow, and decomposition slows; where there is too much nitrogen (plant materials with low C:N), the excess is lost by runoff or by leaching.

Because most individual materials available for composting do not fit this ideal ratio of 30:1, a variety of materials should be mixed when adding to the compost pile. Fresh lawn clippings, weeds, and alfalfa possess high levels of nitrogen (low C:N). Leaves, shredded paper, hedge clippings, cornstalks, crushed corncobs, and sawdust are all good sources of carbon for a compost pile (high C:N).

Food scraps from the kitchen, such as banana peels and apple cores, may attract flies, so they should be covered up with other plant materials, such as leaves or grass clippings. Animal fats and bones are inappropriate in the compost pile because they do not compost easily and may attract dogs, rodents, and other animals. Diseased plant material and weeds that have gone to seed also should not be added.

Making the compost pile

Compost piles can be constructed many different ways. A 30-foot section of snow fence makes an economical enclosure for a compost pile 10 feet in length and 5 feet in width. Three-bin turning units made of concrete or treated lumber make turning compost easy, and produce a usable product in a relatively short time. If you're not comfortable using treated wood, naturally decay-resistant wood, such as redwood or cedar, is an alternative. (See instructions on the next page for building a 3-bin turning unit.) A pit 2½ feet in depth is another type of compost-holding unit. It is easy to conceal and keeps plant material moist for rapid decomposition.

Locate the compost pile in an out-of-the-way area that can be screened from view, yet is accessible to water. Flowering vines or tall annuals grown on and around the compost bin can easily conceal it. A partial shade location is desirable. Full sun may cause excessive drying. Full shade retards drying, but lowers pile temperatures, resulting in slower spring and fall decomposition.

There are no special procedures in preparing compost. With a little experience, each person can develop or adapt measures that meet his or her needs. Best results can be obtained by "stockpiling" materials until there is enough to build a pile that is at least 3 feet by 3 feet square, and 3 feet in height, but no larger than 5 feet by 5 feet square, and 5 feet in height. A mixture of various yard wastes promotes rapid and uniform decomposition. Because smaller particles decompose more rapidly, it is advantageous to chop or shred hedge prunings, cornstalks, and other coarse materials before adding them to the compost pile.

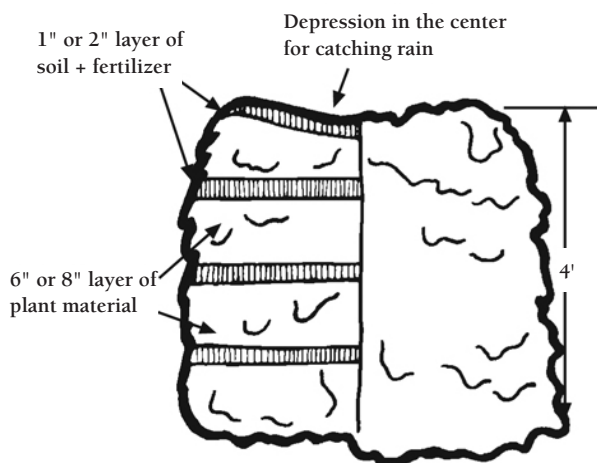

Cross section of a compost pile

Build the pile up in layers. Start with a 6- to 8-inch layer of plant material topped with a 1- or 2-inch layer of garden soil. A topdressing of commercial fertilizer should be added to each layer to provide the nitrogen needed by the microbes. Use 1½ to 2 pints of a complete analysis fertilizer, such as 12-12-12. Continue these layers until the pile is 3 to 5 feet in height.

Because of the remarkable ability of soil and humus to absorb odors, no unpleasant odor comes from a compost pile that is well-aerated and contains within it layers of soil. However, a large quantity of fresh lawn clippings in the pile pack together and prevent good air movement through the pile; the resulting lack of oxygen allows development of offensive odors and slows down decomposition. For efficient and uniform composting, lawn clippings should be mixed with other organic materials.

Adding lime to the compost pile is often recommended because some compost becomes acid. But compost made with plant materials available in Iowa is almost neutral in reaction—even slightly alkaline. Agricultural lime should be added to the pile only if a soil test shows the garden soil to be acid.

A moisture content of 40 to 60 percent promotes multiplication of beneficial microbes in the compost pile. To supply this moisture, each layer of plant debris, soil, and fertilizer should be soaked with water—though too much water causes the leaching of the soluble fertilizer salts. The composting material should feel like a damp sponge—a drop or two of water should drip out when tightly squeezed. The pile should be supplied with moisture during the entire composting process to ensure rapid and complete decomposition.

Heat is generated during the composting process, the pile often reaching 150 to 170°F, temperatures high enough for the destruction of some weed seeds and plant diseases. If the pile is not kept moist enough, the materials may get too hot, becoming *fire-fanged*. The resulting material has a burned appearance, is light in weight, and has no value as compost.

To ensure uniform, rapid decomposition, the pile must be turned regularly to provide the aeration (oxygen). The more frequently the pile is turned, the more rapidly the heat builds. The pile should be turned by bringing the inside material to the outside.

Hastening decomposition

The *decomposition rate* depends upon several factors: type of materials used, size of particles, and amounts of moisture and oxygen present. Some techniques that can be used to speed decomposition of the plant material by the microbes are as follows:

- chop or shred the materials to be composted;
- add a high-nitrogen, complete analysis fertilizer to the pile;
- incorporate barnyard manure into the pile; and
- turn the compost about once a week during the season, adding some water each time.

Each technique hastens decomposition, but best results can be obtained by using all.

Frequently asked questions

1. *Is there a problem composting newspapers and magazines?*

No. Lead is rarely used in printing today. If it were present in the ink, the amount would be so small it would not be hazardous. Shiny, coated, colored paper used in advertisements may not break down as readily as uncoated black-and-white newspaper.

2. *Will the pile decompose faster if I add nitrogen fertilizer?*

Yes. The nitrogen is necessary for the microbes to multiply.

3. *Can lawn clippings that have been treated with herbicides be put on a compost pile?*

Herbicide residues should not be a problem if the materials are thoroughly composted. As an added safety measure, do not collect the clippings for two or three mowings after the herbicide was applied.

4. *Can dog or cat feces be put on the compost pile?*

No. They may contain pathogens that are not killed in the heat of the composting.

5. *How long does it take to reach a finished product?*

A well-managed compost pile containing shredded material that is turned and watered regularly is ready in approximately 2 to 4 months. When finished, the compost is dark brown and has an earthy odor. You will not be able to distinguish individual organic components that went into the pile. A pile or bin containing unshredded materials and left unattended may take a year or longer to decompose. Piles prepared in late fall do not decompose by spring.

Reviewed by Henry G. Taber, extension horticulturist. Originally prepared by Henry G. Taber, extension horticulturist; Linda Naeve and Michael Agnew, former extension horticulturists; and Rex Heer, media graphics artist.

Construction of Stationary 3-Bin Compost Turning Unit

Materials:

- (4) 12' treated 2 × 4s
- (4) 10' treated 2 × 4s
- (1) 12' or (2) 6' 2 × 6s
- (9) 6' cedar 1 × 6s
- (22') of 36" wide ¼" hardware cloth
- (12) ½" × 4" carriage bolts (+ washers and nuts)
- (3 lbs) 16d galvanized nails
 - or (3 lbs) 3" galvanized deck screws
- (½ lb) 8d galvanized casement nails
 - or (½ lb) 2" galvanized deck screws
- (250) poultry wire staples
 - or power stapler with 1" staples

Tools:

- hand saw or circular power saw
- drill with ½" and ⅛" bits
- screwdriver
- hammer
- tin snips
- tape measure
- pencil
- ¾" socket or open-ended wrench
- carpenter's square
- safety glasses
- ear protection

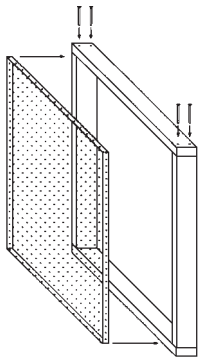

Build Dividers:

- Cut each 12' 2 × 4 into (2) 36" pieces and (2) 33" pieces.
- Screw or nail (2) 36" pieces and (2) 33" pieces into a 36" square.
- Repeat for other three dividers.
- Cut (4) 36" long sections of hardware cloth.
- Bend back edges 1½".
- Stretch hardware cloth inside each frame.
- Check for squareness and staple screen every 4" around the edges.

Assemble Frame, part 1:

- Cut the (4) 10' 2 × 4s to 111½" lengths.
- Position (2) 111½" 2 × 4s on top of the dividers.
- Drill ½" holes 1" from inside edge of 111½" 2 × 4s, 1¾" and 37¾" from both ends, through centerline of dividers.
- Secure with carriage bolts, washers, and nuts, but do not tighten.

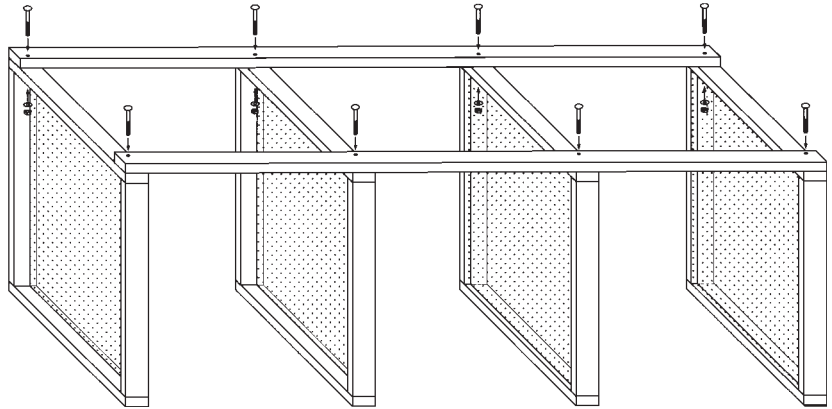

Assemble Frame, part 2:

- Turn unit and use the same process to install the top back 111½" 2 × 4.
- Install the top front 111½" 2 × 4 so that the front edge is 2½" back from the front edge of dividers.
- Using a carpenter's square or measuring between opposite corners (equal diagonals mean the box is square), make sure bin is square and tighten all bolts securely.
- Fasten a 9' long piece of hardware cloth securely to back of frame with staples every 4".

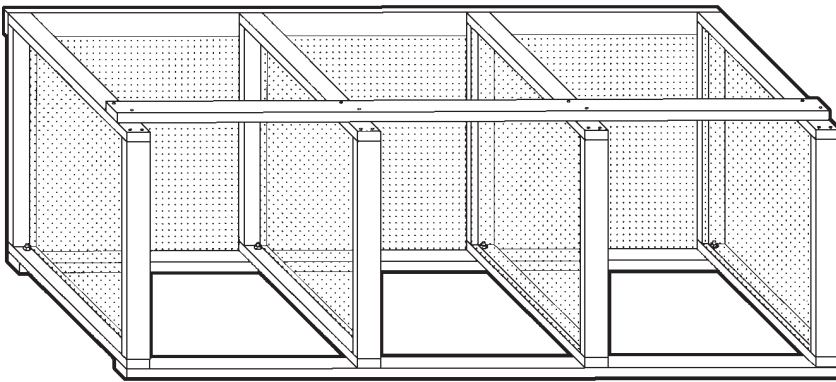

Install Runners for Cedar Slats:

- Cut (4) 36" long pieces of 2 × 6s for front slat runners.
- Rip cut (2) of these to 4½" wide and nail or screw securely to front of outside dividers, flush with top and outside edges (save remainder of rip cuts for use as back slat runners.)
- Center the remaining full-width boards on the front of the inside dividers, flush with top edge and fasten with nails or screws.
- Cut (1) 36" long piece of 2 × 6 for back slat runners, and rip into (4) 1" pieces.
- Attach back slat runners on sides of dividers parallel to front runners leaving a 1" gap for slats.
- Cut all 1 × 6 cedar into slats 32" long.

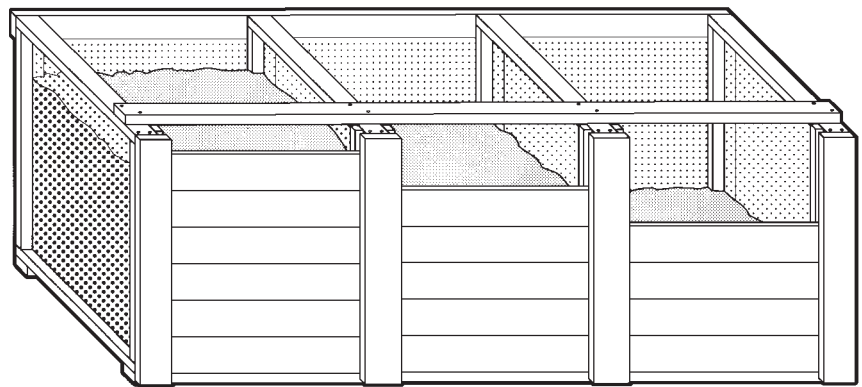

File: Hort and LA 1